

Order Example (주문예)

HSSP 095N

HSSP095N 300R B200 D:3 3990L 3SETS
 Type Radius Width Divider Length Q'ty

Chain, Cross Section

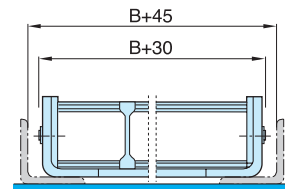
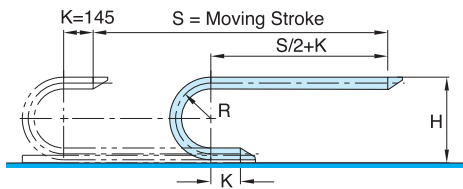
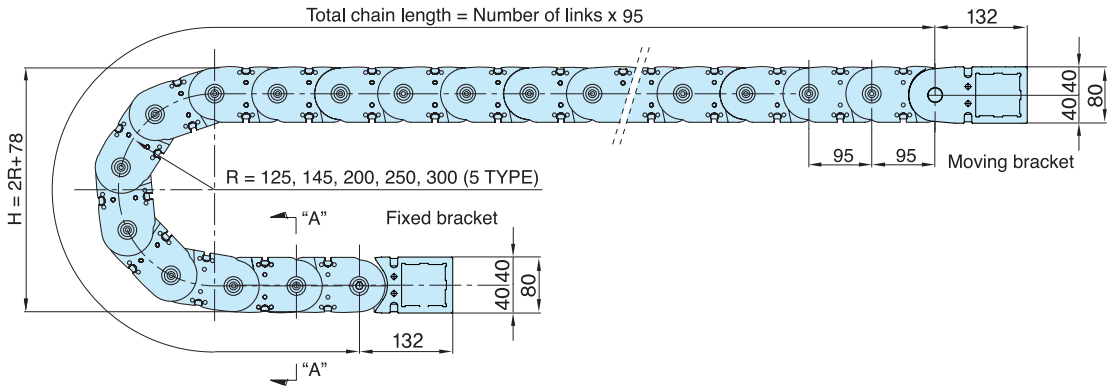

Length $L = \frac{S}{2} + \pi R + 290$

Radius	R	125	145	200	250	300
Height	H	328	368	478	578	678

Divider

Cable/Hose d _{max}	Ø52							
Frame Dim. "B"	80	100	125	150	200	250	300	
Divider	Min. No.	0	0	1	1	2	3	4
	Max. No.	3	3	4	5	6	7	8

if "B" > 300, "WIDE BAR" (OPTION)

* Eng. Plastic(표준), Aluminum(옵션)

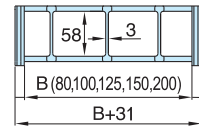

A-A Cross Section

Brackets * Eng. Plastic(표준), Steel(장거리 옵션)

