

Order Example (주문예)

HSSP 070N

HSSP070N 145R B200 D:3 2940L 3SETS
 Type Radius Width Divider Length Q'ty

Chain, Cross Section

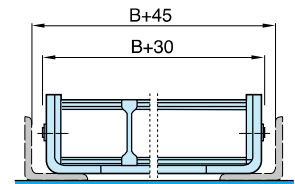
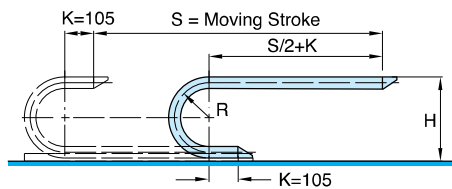
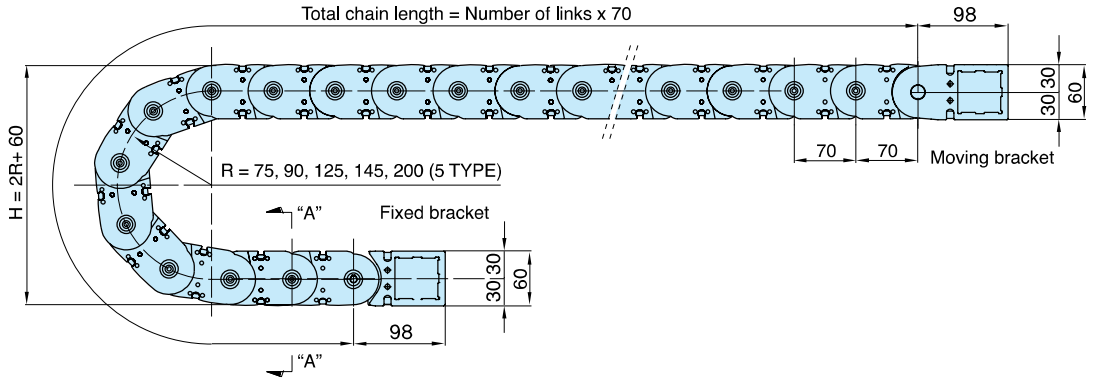

Guide Rail

Length $L = \frac{S}{2} + \pi R + 210$

Radius	R	75	90	125	145	200
Height	H	210	240	310	350	460

Divider

Cable/Hose d_{max}	$\varnothing 32$						
Frame Dim. "B"	80	100	125	150	200	250	
Divider	Min. No.	0	0	1	1	2	3
	Max. No.	3	3	4	5	6	7

* Eng. Plastic(표준), Aluminum(옵션)

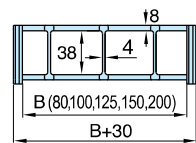

A-A Cross Section

Brackets * Eng. Plastic(표준), Steel(장거리 옵션)

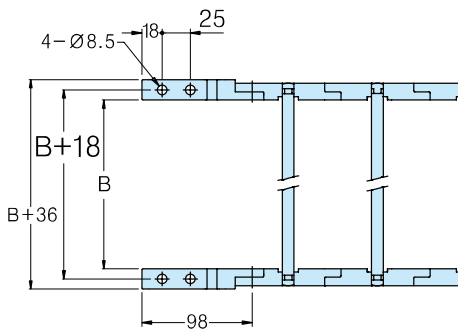

Fixed Bracket

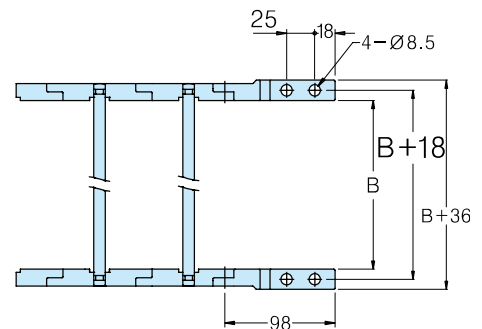

Moving Bracket